

ELECTRONIC THERMOSTAT

ETR 011



- > Large setting range
- > Small hysteresis
- > Status indicator (LED)
- > Change-over contact
- > Clip fixing

The electronic thermostat is used for controlling heating and cooling equipment, filter fans or signal devices. The thermostat registers the surrounding air and can switch both inductive and resistive loads via relay with change-over contact. The LED integrated in the adjustment knob is lit when the NC is closed. (e.g. when a connected heater is operating).



TECHNICAL DATA

Switch temperature difference	4 K (± 1K tolerance) at +20 °C (+68 °F)
Sensor element	NTC
Reaction time	approx. 5 sec.
Contact type	change-over contact (relay)
Service life	> 50,000 cycles
Max. switching capacity (relay output)	AC 240 V / AC 120 V, 8 (1.6) A DC 100 W at DC 24 V
Max. inrush current	AC 16 A for 10 sec.
Optical indicator	LED
Connection	5-pole terminal, clamping torque 0.5 Nm max.: rigid/stranded ¹ wire 2.5 mm ² (AWG 14)
Mounting	clip for 35 mm DIN rail, EN 60715
Casing	plastic according to UL 94V-0, light grey
Dimensions	64.5 x 42 x 38 mm
Weight	approx. 70 g
Fitting position	vertical
Operating/Storage temperature	-40 to +85 °C (-40 to +185 °F)
Operating/Storage humidity	max. 90 % RH (non-condensing)
Protection type	IP20

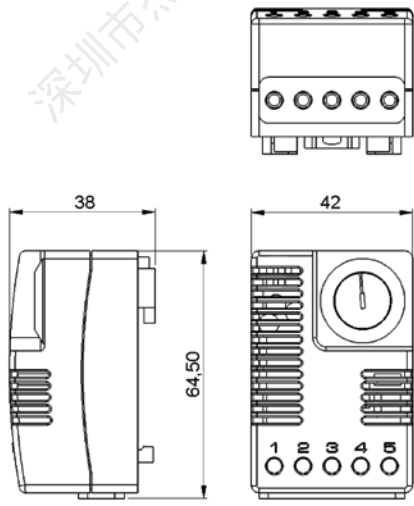

Connection diagram

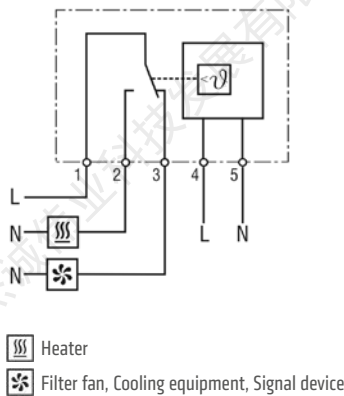

¹ When connecting with stranded wires, wire end ferrules must be used.

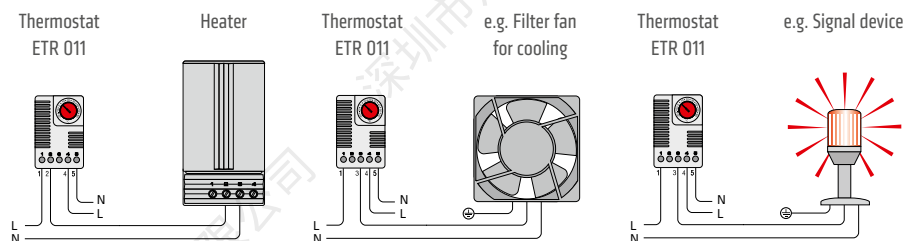

Art. No.	Operating voltage	Setting range	Approvals		
01131.0-00	AC 230 V, 50/60 Hz	-20 to +60 °C	VDE	UL File No. E164102	EAC
01131.9-00	AC 120 V, 50/60 Hz	-4 to +140 °F	-	UL File No. E164102	EAC